

All Stainless Steel Pressure Gauge

Bayonet Ring (Open Front)

P-1A

- ✦ Disc Blow Out Protection
- ✦ Dry or Liquid Filled
- ✦ Open Front / Removable Ring
- ✦ Excellent Corrosion Resistance
- ✦ Stainless Steel Case
- ✦ SS316L Internals

HAWK 21L and 21B series bourdon tube all stainless steel pressure gauges are designed to fulfill the requirements of high quality from various industries. The wetted parts can be in 316L stainless steel. The 316LSS construction pressure gauges are good in use on demanding applications where corrosion resistance, rugged environment resistance and reliable operation are required.

Liquid Filling or dampened movement is available to diminish the effects of vibration, pulsation and shock and further enhances the gauge life. These gauges are ideal to use combined with diaphragm seal where re-calibration is required.

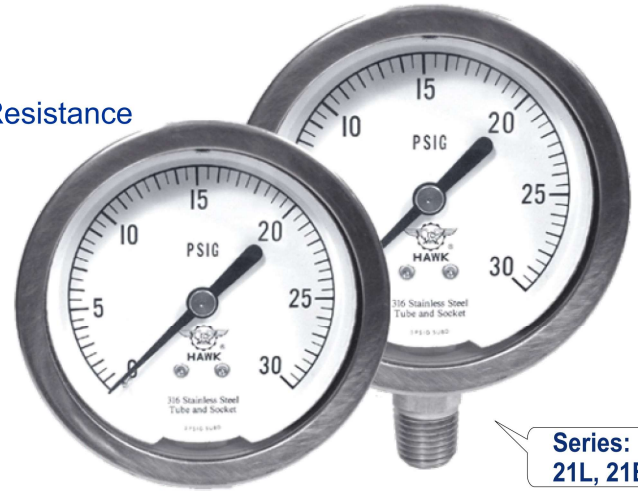

Series:
21L, 21B

Typical Application

- Petrochemical and chemical processing
- Medical and pharmaceutical industry
- Industrial OEM equipments
- Hydraulic monitoring systems
- Power generating stations
- Offshore oil platforms
- Pneumatic systems
- Level measurement

Specifications

Operating

Steady: 75%*full scale value
Pulsation: 50%*full scale value
Sudden: 100%*full scale value

The appropriate operating range falls in the middle half of the gauge (25% to 75% of full scale). If you choose the unsuitable range, the fatigue of bourdon tube may be resulted. HAWK Supplies a wide selection of range from vacuum to 15000 PSI including compound range.

Temperature limit

Ambient:
- 40 to 100°C(Dry Gauge)
- 10 to 65°C(Glycerin Filled Gauge)
- 50 to 80°C(Silicon Filled Gauge)
Media: max 125°C(Standard)

Temperature effect

Accuracy of measurement will be effected by the temperature change. This inaccuracy may as high as $\pm 0.3\%$ for 12°C temperature change.

Dial Size

2 1/2"(63mm), 3 1/2"(90mm)

Case&Ring

Stainless Steel 304(SS316-option), polished bayonet ring

Socket

316L Stainless Steel-Bottom connection
316 Stainless Steel-Back connection

Movement

Stainless steel movement

Bourdon Tube

316L-Stainless Steel
30"Hg(Vac) to 900PSI...C-type
1000 to 15000PSI...Helical type

Window

Tempered safety glass-standard
Plain glass, Polycarbonate or laminated safety glass-optional.

Pointer

Anodized aluminum with black finish.

Accuracy

$\pm 2-1-2\%$ of span
(Grade A to ASME B40.1)

Scale

PSI, kPa, Mpa, bar, kg/cm², inHg, cmHg, torr, mmHg (single or dual scale)

Connection

1/4", 1/8" NPT standard, JIS, DIN, M14*1.0 available

Mounting

Stem or Flushing(U-clamp/Flange) mounting.

Weatherproof

NEMA 4X/IP65 enclosure

All Stainless Steel Pressure Gauge

Bayonet Ring (Open Front)

P-1A

Dimensions

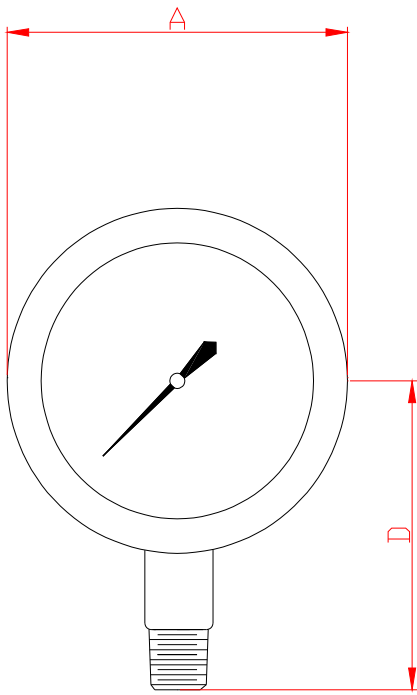

21L (Bottom Connection)

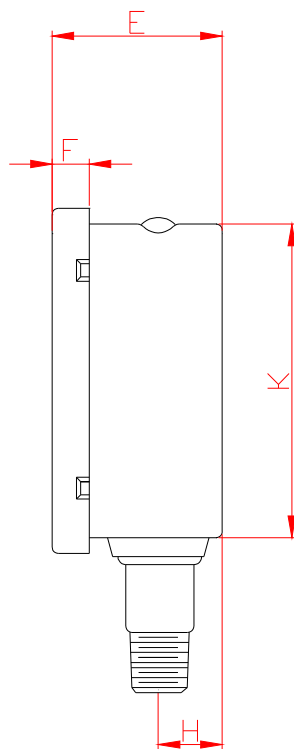

21B (Center Back Connection, Lower Back Connection on request)

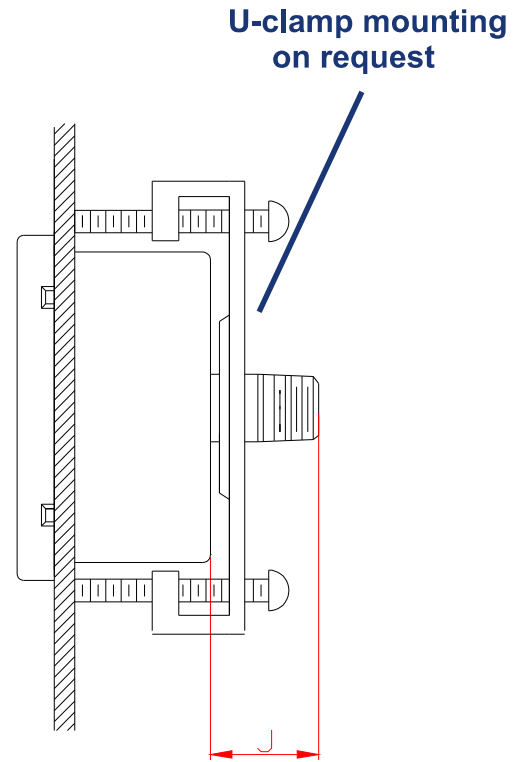

Dimensions, in.(mm)

Type No	Dial Size	A	B	C	D	E	F	G	H	J	K	L	Weight
21L	2.5"	2.67" (68)			2.21" (56)	1.26" (32)	0.39" (10)		0.47" (12)		2.44" (62)		0.15-0.20 Kg
21B	2.5"	2.67" (68)				1.26" (32)	0.39" (10)			0.91" (23)	2.44" (62)		0.15-0.20 Kg

Type No	Dial Size	A	B	C	D	E	F	G	H	J	K	L	Weight
21L	3.5"	4.01" (102)			3.07" (78)	1.34" (34)	0.47" (12)		0.47" (12)		3.58" (91)		0.30-0.37 Kg
21B	3.5"	4.01" (102)				1.34" (34)	0.47" (12)			0.91" (23)	3.58" (91)		0.30-0.37 Kg



Since 1971

All Stainless Steel Pressure Gauge

Bayonet Ring (Open Front)

P-1A

Dimensions

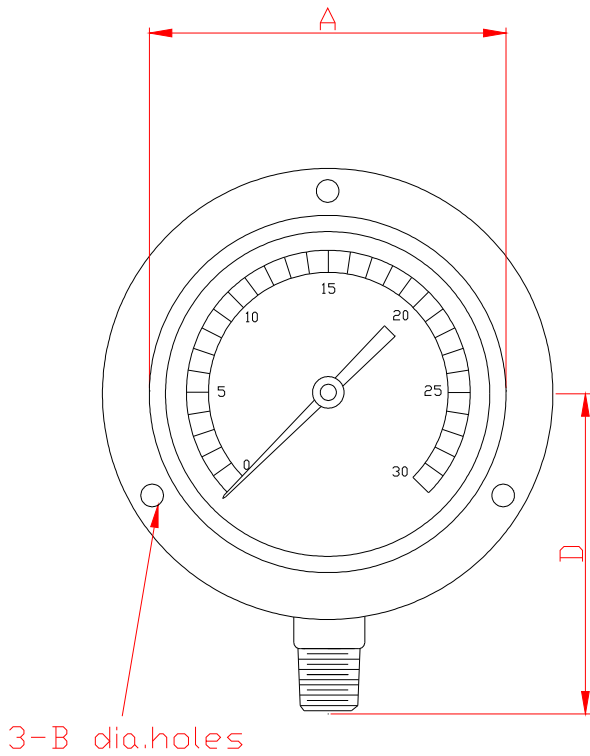

21L (Bottom Connection)

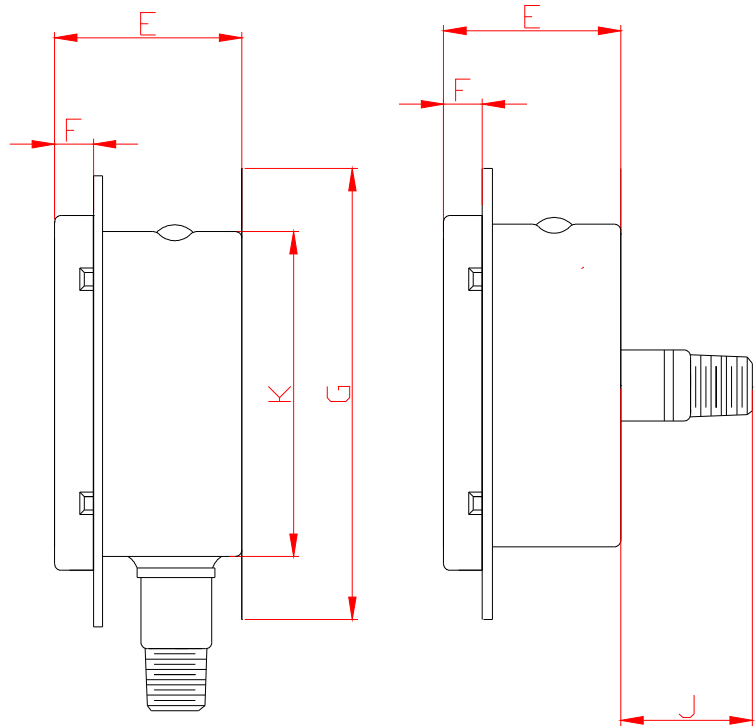

21B (Center Back Connection, Lower Back Connection on request)

Front Flange

Dimensions, in.(mm)

Type No	Dial Size	A	B	C	D	E	F	G	H	J	K	L	Weight
21L	2.5"	2.67" (68)	2.67" (4)	2.67" (80)	2.21" (56)	1.26" (32)	0.39" (10)	3.46" (88)			2.44" (62)		0.18-0.25 Kg
21B	2.5"	2.67" (68)	2.67" (4)	2.67" (80)		1.26" (32)	0.39" (10)	3.46" (88)		0.91" (23)	2.44" (62)		0.18-0.25 Kg

Type No	Dial Size	A	B	C	D	E	F	G	H	J	K	L	Weight
21L	3.5"	4.01" (102)	0.24" (6)	4.72" (120)	3.07" (78)	1.34" (34)	0.47" (12)	5.16" (131)			3.58" (91)		0.37-0.45 Kg
21B	3.5"	4.01" (102)	0.24" (6)	4.72" (120)		1.34" (34)	0.47" (12)	5.16" (131)		0.91" (23)	3.58" (91)		0.37-0.45 Kg

All Stainless Steel Pressure Gauge

Bayonet Ring (Open Front)

P-1A

Dimensions

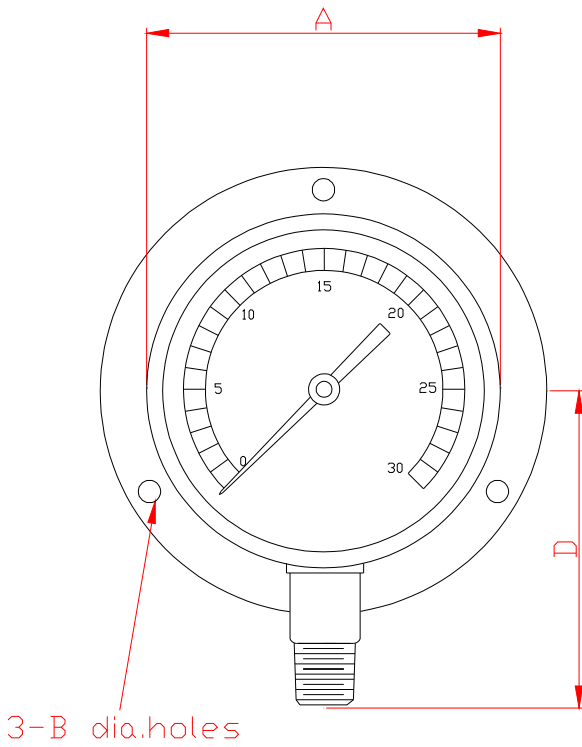

21L(Bottom Connection)

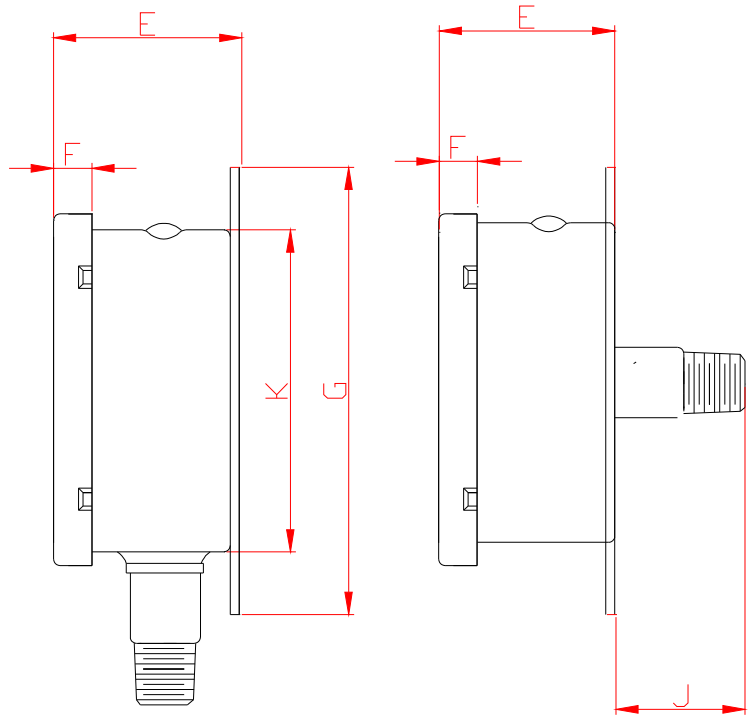

**21B(Center Back Connection)
Lower Back Connection on request**

Back Flange

Dimensions, in.(mm)

Type No	Dial Size	A	B	C	D	E	F	G	H	J	K	L	Weight
21L	2.5"	2.67" (68)	2.67" (4)	2.67" (80)	2.21" (56)	1.26" (32)	0.39" (10)	3.46" (88)			2.44" (62)		0.18-0.25 Kg
21B	2.5"	2.67" (68)	2.67" (4)	2.67" (80)		1.26" (32)	0.39" (10)	3.46" (88)		0.91" (23)	2.44" (62)		0.18-0.25 Kg

Type No	Dial Size	A	B	C	D	E	F	G	H	J	K	L	Weight
21L	3.5"	4.01" (102)	0.24" (6)	4.72" (120)	3.07" (78)	1.34" (34)	0.47" (12)	5.16" (131)			3.58" (91)		0.37-0.45 Kg
21B	3.5"	4.01" (102)	0.24" (6)	4.72" (120)		1.34" (34)	0.47" (12)	5.16" (131)		0.91" (23)	3.58" (91)		0.37-0.45 Kg



HAWK

Since 1971

All Stainless Steel Pressure Gauge

Bayonet Ring (Open Front)

P-1A

Pressure Range

- The other scales and ranges(DIN) are available in request.
- Not all listed ranges and scales are in stock, consult your distributors for available.

Pressure Ranges

SINGLE SCALE				DUAL SCALE									
PSI		Bar		KPa		Kg/cm2		Bar & PSI		Kpa & PSI		Kg/cm2 & PSI	
Code	Range	Code	Range	Code	Range	Code	Range	Code	Range	Code	Range	Code	Range
P29	6	R1	0.4	K29	40	G1	0.4	X9	0.4 Bar/PSI	Y16	40 kPa/PSI	W9	0.4 Kg/cm2/PSI
P30	8	R2	0.6	K31	60	G2	0.6	X11	0.6 Bar/PSI	Y18	60 kPa/PSI	W11	0.6 Kg/cm2/PSI
P32	15	R3	1	K33	100	G3	1	X12	1 Bar/PSI	Y22	100 kPa/PSI	W12	1 Kg/cm2/PSI
P33	20	R4	1.6	K34	160	G4	1.6	X13	1.6 Bar/PSI	Y25	160 kPa/PSI	W13	1.6 Kg/cm2/PSI
P35	30	R5	2	K35	200	G5	2	X14	2 Bar/PSI	Y26	200 kPa/PSI	W14	2 Kg/cm2/PSI
P37	40	R6	2.5	K36	250	G6	2.5	X15	2.5 Bar/PSI	Y27	250 kPa/PSI	W15	2.5 Kg/cm2/PSI
P38	50	R7	3	K37	300	G7	3	X16	3 Bar/PSI	Y28	280 kPa/PSI	W16	3 Kg/cm2/PSI
P39	60	R8	4	K38	400	G9	4	X18	4 Bar/PSI	Y31	400 kPa/PSI	W18	4 Kg/cm2/PSI
P40	80	R9	5	K39	500	G10	5	X19	5 Bar/PSI	Y32	500 kPa/PSI	W19	5 Kg/cm2/PSI
P40A	85	R11	6	K40	600	G11	6	X20	6 Bar/PSI	Y33	600 kPa/PSI	W20	6 Kg/cm2/PSI
P41	100	R12	7	K41	700	G12	7	X21	7 Bar/PSI	Y34	700 kPa/PSI	W21	7 Kg/cm2/PSI
P42	150	R13	10	K42	1000	G13	10	X22	10 Bar/PSI	Y36	1000 kPa/PSI	W22	10 Kg/cm2/PSI
P43	160	R13A	11	K42A	1100	G13A	11	X23	11 Bar/PSI	Y36A	1100 kPa/PSI	W23	11 Kg/cm2/PSI
P43A	180	R13B	14	K42B	1400	G13C	14	X24	14 Bar/PSI	Y37	1400 kPa/PSI	W24	14 Kg/cm2/PSI
P44	200	R13C	15	K42C	1500	G13B	15	X25	15 Bar/PSI	Y38	1500 kPa/PSI	W25	15 Kg/cm2/PSI
P45	250	R14	16	K43	1600	G14	16	X26	16 Bar/PSI	Y39	1600 kPa/PSI	W26	16 Kg/cm2/PSI
P46	300	R15	20	K44	2000	G15	20	X28	20 Bar/PSI	Y40	2000 kPa/PSI	W28	20 Kg/cm2/PSI
P47	350	R16	25	K45	2500	G16	25	X29	25 Bar/PSI	Y41	2500 kPa/PSI	W29	25 Kg/cm2/PSI
P48	400	R16B	28	K55A	2800	G16A	28	X30	28 Bar/PSI	Y42	2800 kPa/PSI	W30	28 Kg/cm2/PSI
P48A	450	R17	30	K46	3000	G17	30	X31	30 Bar/PSI	Y43	3000 kPa/PSI	W31	30 Kg/cm2/PSI
P49	500	R18	35	K47	3500	G18	35	X32	35 Bar/PSI	Y44	3500 kPa/PSI	W32	35 Kg/cm2/PSI
P50	600	R19	40	K48	4000	G19	40	X33	40 Bar/PSI	Y45	4000 kPa/PSI	W33	40 Kg/cm2/PSI
P51	800	R20	50	K49	5000	G20	50	X34	50 Bar/PSI	Y46	5000 kPa/PSI	W34	50 Kg/cm2/PSI
P51A	850	R21	60	K50	6000	G21	60	X35	60 Bar/PSI	Y47	6000 kPa/PSI	W35	60 Kg/cm2/PSI
P52	1,000	R22	70	K51	7000	G22	70	X36	70 Bar/PSI	Y48	7000 kPa/PSI	W36	70 Kg/cm2/PSI
P53	1,500	R23	100	K52	10000	G23	100	X39	100 Bar/PSI	Y50	10000 kPa/PSI	W39	100 Kg/cm2/PSI
P53A	1,600	R23A	140	K52B	14000	G23A	140	X40	140 Bar/PSI	Y51	14000 kPa/PSI	W40	140 Kg/cm2/PSI
P54	2,000	R24	160	K53	16000	G24	160	X42	160 Bar/PSI	Y53	16000 kPa/PSI	W42	160 Kg/cm2/PSI
P56	3,000	R25	200	K54	20000	G25	200	X43	200 Bar/PSI	Y54	20000 kPa/PSI	W43	200 Kg/cm2/PSI
P57	3,500	R26	250	K55	25000	G26	250	X44	250 Bar/PSI	Y55	25000 kPa/PSI	W44	250 Kg/cm2/PSI
P58	4,000	R26A	280	K55A	28000	G26A	280	X44A	280 Bar/PSI	Y56	28000 kPa/PSI	W44A	280 Kg/cm2/PSI
P58A	4,250	R27	300	K56	30000	G27	300	X45	300 Bar/PSI	Y57	30000 kPa/PSI	W45	300 Kg/cm2/PSI
P59	5,000	R28	350	K56A	35000	G28	350	X46	350 Bar/PSI	Y58	35000 kPa/PSI	W46	350 Kg/cm2/PSI
P60	6,000	R29	400	K57	40000	G29	400	X47	400 Bar/PSI	Y59	40000 kPa/PSI	W47	400 Kg/cm2/PSI
P60B	7,000	R30	500	K58	50000	G30	500	X48	500 Bar/PSI	Y60	50000 kPa/PSI	W48	500 Kg/cm2/PSI
P61	8,000	R31	600	K59	60000	G31	600	X49	600 Bar/PSI	Y61	60000 kPa/PSI	W49	600 Kg/cm2/PSI
P62	10,000	R33	700	K60	70000	G32	700	X50	700 Bar/PSI	Y62	70000 kPa/PSI	W50	700 Kg/cm2/PSI
P63	15,000	R33	1000	K61	100000	G33	1000	X52	1000 Bar/PSI	Y64	100000 kPa/PSI	W52	1000 Kg/cm2/PSI
P64	20,000	R33A	1400	K61A	140000	G33A	1400	X53	1400 Bar/PSI	Y65	140000 kPa/PSI	W53	1400 Kg/cm2/PSI
P65	25,000	R34	1600	K62	160000	G344	1600	X55	1600 Bar/PSI	Y67	160000 kPa/PSI	W55	1600 Kg/cm2/PSI



HAWK

Since 1971

All Stainless Steel Pressure Gauge

Bayonet Ring (Open Front)

P-1A

Pressure Range

Vacuum Ranges

SINGLE SCALE				DUAL SCALE									
InHg		Bar		KPa		Kg/cm2		Bar & PSI		Kpa & PSI		Kg/cm2 & PSI	
Code	Range	Code	Range	Code	Range	Code	Range	Code	Range	Code	Range	Code	Range
PV1	-30/0	RV1	-1/0	KV1	-0.04	GV1	-1/0	XV1	-1 Bar/PSI	YV1	-100 kPa/PSI	WV1	-76 cmHg/inHg

Compound Ranges

SINGLE SCALE				DUAL SCALE									
PSI		Bar		KPa		Kg/cm2		Bar & PSI		Kpa & PSI		Kg/cm2 & PSI	
Code	Range	Code	Range	Code	Range	Code	Range	Code	Range	Code	Range	Code	Range
PCA1	VAC/8.5	RCA	-1/0.6	KOQ	-100/60	GCA	-1/0.6	XCA	-1/0.6 Bar/PSI	YCA	-100/60 kPa/PSI	WCA	-76cmHg/0.6 Kg/cm2
PCA	VAC/15	RCB	-1/1	KOR	-100/100	GCB	-1/1	XCB	-1/1 Bar/PSI	YCB	-100/100 kPa/PSI	WCB	-76cmHg/1 Kg/cm2
		RCC	-1/1.5	KOS	-100/150	GCC	-1/1.5	XCC	-1/1.5 Bar/PSI	YCC	-100/150 kPa/PSI	WCC	-76cmHg/1.5 Kg/cm2
PCB	VAC/30	RCD	-1/2	KOS1	-100/200	GCD	-1/2	XCD	-1/2 Bar/PSI	YCD	-100/200 kPa/PSI	WCD	-76cmHg/2 Kg/cm2
		RCE	-1/2.5	KOS2	-100/250	GCE	-1/2.5	XCE	-1/2.5 Bar/PSI	YCE	-100/250 kPa/PSI	WCE	-76cmHg/2.5 Kg/cm2
		RCF	-1/3	KOT	-100/300	GCF	-1/3	XCF	-1/3 Bar/PSI	YCF	-100/300 kPa/PSI	WCF	-76cmHg/3 Kg/cm2
PCC	VAC/60	RCG	-1/4	KOT2	-100/400	GCG	-1/4	XCG	-1/4 Bar/PSI	YCG	-100/400 kPa/PSI	WCG	-76cmHg/4 Kg/cm2
		RCH	-1/5	KOU	-100/500	GCH	-1/5	XCH	-1/5 Bar/PSI	YCH	-100/500 kPa/PSI	WCH	-76cmHg/5 Kg/cm2
PCD	VAC/100	RCJ	-1/7	KOU2	-100/700	GCJ	-1/7	XCJ	-1/7 Bar/PSI	YCJ	-100/700 kPa/PSI	WCJ	-76cmHg/7 Kg/cm2
		RCK	-1/9	KOV	-100/900	GCK	-1/9	XCK	-1/9 Bar/PSI	YCK	-100/900 kPa/PSI	WCK	-76cmHg/9 Kg/cm2
PCE	VAC/150	RCL	-1/10	KOV1	-100/1000	GCL	-1/10	XCL	-1/10 Bar/PSI	YCL	-100/1000 kPa/PSI	WCL	-76cmHg/10 Kg/cm2
PCF	VAC/160	RCM	-1/11	KOV2	-100/1100	GCM	-1/11	XCM	-1/11 Bar/PSI	YCM	-100/1100 kPa/PSI	WCM	-76cmHg/11 Kg/cm2
PCG	VAC/200	RCO	-1/14	KOV4	-100/1400	GCO	-1/14	XCO	-1/14 Bar/PSI	YCO	-100/1400 kPa/PSI	WCO	-76cmHg/14 Kg/cm2
		RCP	-1/15	KOW	-100/1500	GCP	-1/15	XCP	-1/15 Bar/PSI	YCP	-100/1500 kPa/PSI	WCP	-76cmHg/15 Kg/cm2
		RCR	-1/19	KOW2	-100/1900	GCR	-1/19	XCR	-1/19 Bar/PSI	YCR	-100/1900 kPa/PSI	WCR	-76cmHg/19 Kg/cm2
PCH	VAC/300	RCS	-1/20	KOW3	-100/2000	GCS	-1/20	XCS	-1/20 Bar/PSI	YCS	-100/2000 kPa/PSI	WCS	-76cmHg/20 Kg/cm2
		RCT	-1/24	KOX	-100/2400	GCT	-1/24	XCT	-1/24 Bar/PSI	YCT	-100/2400 kPa/PSI	WCT	-76cmHg/24 Kg/cm2
		RCU	-1/25	KOX1	-100/2500	GCU	-1/25	XCU	-1/25 Bar/PSI	YCU	-100/2500 kPa/PSI	WCU	-76cmHg/25 Kg/cm2
PCI	VAC/400	RCV	-1/27	KOX2	-100/2700	GCV	-1/27	XCV	-1/27 Bar/PSI	YCV	-100/2700 kPa/PSI	WCV	-76cmHg/27 Kg/cm2
		RCW	-1/30	KOY	-100/3000	GCW	-1/30	XCW	-1/30 Bar/PSI	YCW	-100/3000 kPa/PSI	WCW	-76cmHg/30 Kg/cm2
PCJ	VAC/500	RCW1	-1/35	KOZ	-100/3500	GCW1	-1/35	XCX	-1/35 Bar/PSI	YCX	-100/3500 kPa/PSI	WCX	-76cmHg/35 Kg/cm2
PCK	VAC/600	RCX	-1/40	KOZ1	-100/4000	GCX	-1/40	XCX	-1/40 Bar/PSI	YCY	-100/4000 kPa/PSI	WCY	-76cmHg/40 Kg/cm2
		RCY	-1/50	KOZ2	-100/5000	GCY	-1/50	XCZ	-1/50 Bar/PSI	YCY	-100/5000 kPa/PSI	WCZ	-76cmHg/50 Kg/cm2
		RCZ	-1/60	KOZ3	-100/6000	GCZ	-1/60	XC1	-1/60 Bar/PSI	YCY	-100/6000 kPa/PSI	WC1	-76cmHg/60 Kg/cm2
		RC0	-1/100	KOZ7	-100/10000	GC0	-1/100	XC2	-1/100 Bar/PSI	YCY	-100/10000 kPa/PSI	WC2	-76cmHg/100 Kg/cm2

Order Information

Example:

Series	Model	Dial	Wetted Parts	Process Connection	Pressure Range	Option
P-1A-21	L	25	W	M	4	P 4 1 H-Z G Z L
	L- Lower (Bottom) Connection B- Lower (Back) Connection	25-2.5" (63mm) 35-3.5" (90mm)	W-316LSS	F-Female M-Male	4-1/4"NPT 8-1/8"NPT 7-7/16"UNF 9-9/16"UNF E-G1/4 F-G1/8 B-R1/4 C-R1/8	ZG- Glycerine Filled ZL- Laminated Safety Glass Lens Other options please check the next page
				0L- Others	Please refer to the range table and write down the code you need. Vacuum Compound Pressure	
				Other connections are available on request		



Since 1971

All Stainless Steel Pressure Gauge

Bayonet Ring (Open Front)

P-1A

Option

Certificate of Accuracy (NIST)

ZI

Certificate of Accuracy (Factory)

ZC



Certificate of Accuracy (TAF)

ZE

Improved Accuracy In 2 Degree

OW

Improved Accuracy 0.5% (Grade 2A-ASME B40.1)

Z1

Back Flange Case

ZB



Front Flange Case

ZF



Disc Blow Out Back

ZD



316SS Case

Z3

Stainless Steel U-Clamp Bracket

ZU



Dampened Movement

ZM

Glycerine Filled

ZG

Double Restrictor Screw

ZR

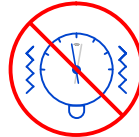

Halocarbon Filled

ZH

Dry But Silicone Fillable

Z9

Fluorolube Filled

ZO

Silicone Filled

ZS

NACE-MR0175-2002 Heat Treatment

ZN



Cleaned for Oxygen Service

ZX



All Stainless Steel Pressure Gauge

Bayonet Ring (Open Front)

P-1A

Option

ZQ Movement with PTFE or Titanium Coated Gear

12 O'clock Connection



0F

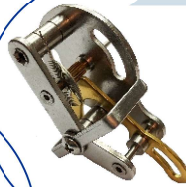

0D

3 O'clock Connection



0E

9 O'clock Connection



Stop Pin at 6 O'clock

0M



Red Pointer

0A



FCFC Painting

0J

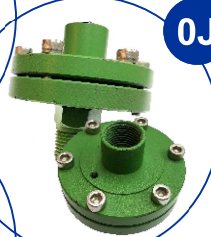

Polycarbonate Lens

ZP



0P

Stop Pin

ZT

Tempered Safety Glass Lens

Laminated Safety Glass Lens

ZL

Degree C Scale

0I

09

Receiver Scale 0...30 PSI

Altitude Scale

Z8

Z4

Receiver Scale 3...15 PSI

Retard Scale

Z7

Z5

Ammoniated Scale

Z6

Refrigerant Scale

All Stainless Steel Pressure Gauge

Bayonet Ring (Open Front)

P-1A

Option

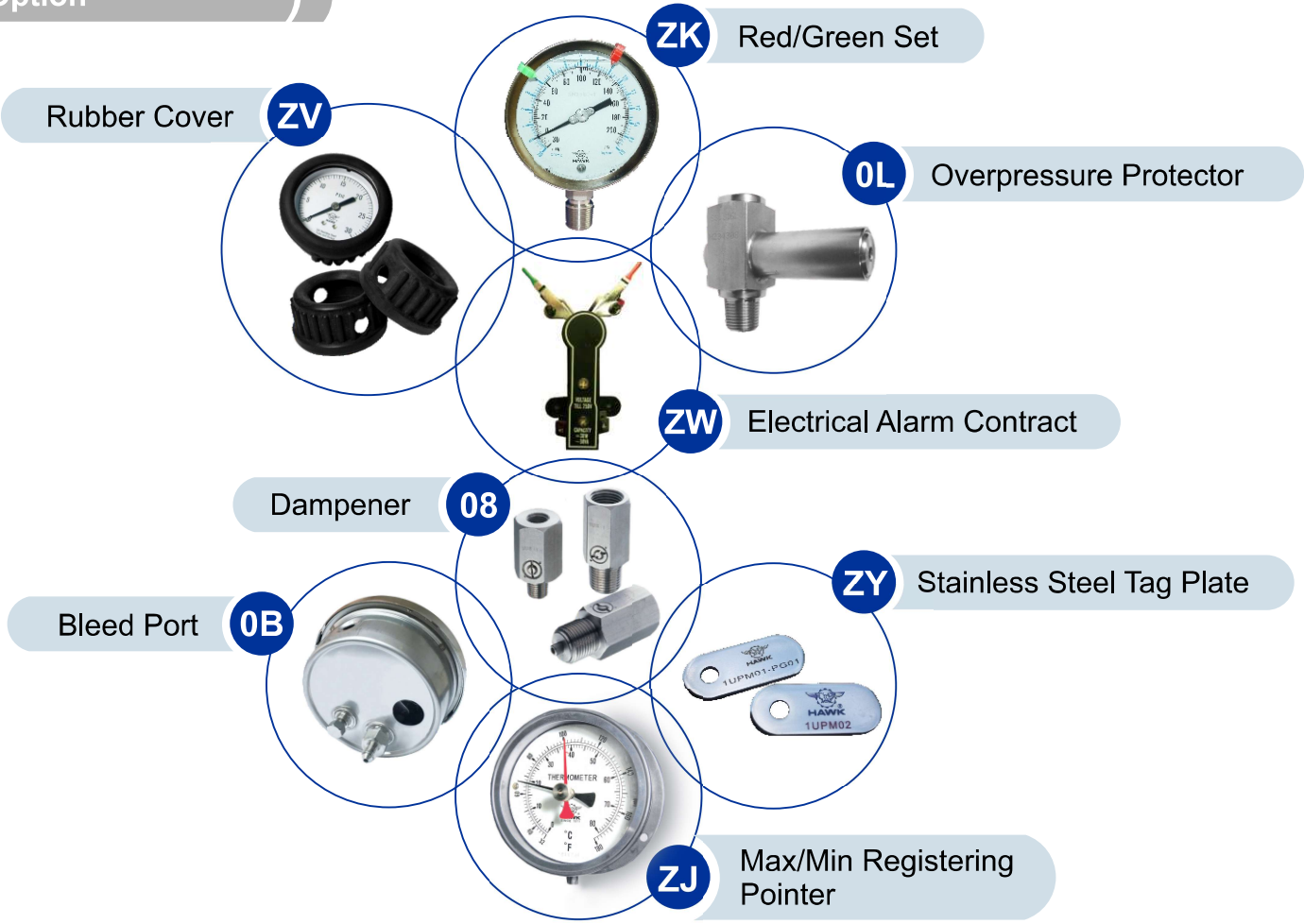

- ZV** Rubber Cover
- ZK** Red/Green Set
- OL** Overpressure Protector
- ZW** Electrical Alarm Contract
- O8** Dampener
- ZY** Stainless Steel Tag Plate
- OB** Bleed Port
- ZJ** Max/Min Registering Pointer

Accessories

Please refer to HAWK diaphragm seal and accessories data sheets for detailed information.

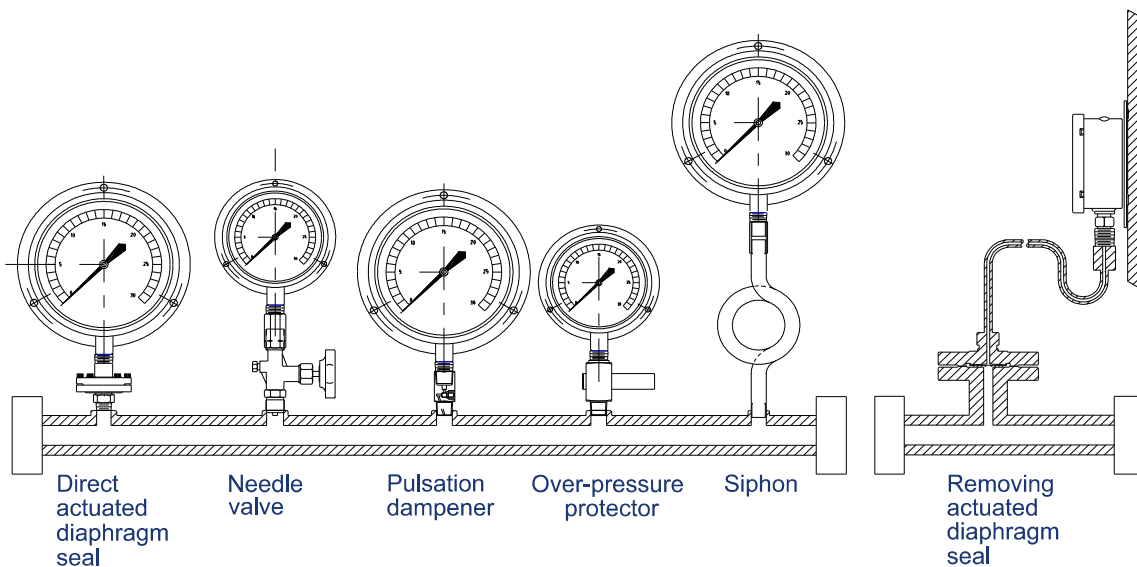

All Stainless Steel Pressure Gauge

Bayonet Ring (Open Front)

P-1A

Limited Warranty and Liability

HAWK GAUGE CO.,LTD warrants all its mechanical instruments to be free from defects in materials and workmanship. HAWK agrees to repair or replace any pressure gauges if returned to our factory, transportation charges prepaid, and after which examination reveals is to be defective due to faculty workmanship or material. This warrant should not apply to subject to the following terms and conditions:

- A.** The product has not been subjected to misuse, neglect, abuse , accident, incorrect mounting, improper use or misapplication such as negligence, accident, vandalism, shock or vibration.
- B.** The performance of any system of which HAWK's products are a component part.
- C.** The product has not been exposed to any other service, range or environment of greater severity than that for which the products were designed.
- D.** The product has not been altered or repaired by anyone except HAWK GAUGE or its authorized service agencies.
- E.** The serial number or date code has not been removed, defaced or changed.
- F.** The actual pressure&temperature occurring exceed the values specified for HAWK Process gauge.

Unless otherwise specified in a manual or warranty card, or agree to in a writing signed by HAWK GAUGE office, HAWK Process gauge products shall be warranted for one years from the date of sale.

This warranty is in lieu of all other warranties expressed or implied, and of all obligations or liabilities on its part for damages including but not limited to consequential damages, following the use of misuse of instruments sold by it.

No agent is authorized to assume for it any liability except as set forth above.

Note

HAWK GAUGE CO.,LTD reserves the right to make product improvements and change its specifications at any time stated throughout this brochure without notification. Please contact the factory on all critical dimensions and specifications for verification.

HAWK GAUGE is not expert in the customer's technical field and therefore doesn't warrant suitability of it's product for the application selected by customer.



Data Sheet No: MKDP1A21A2-E